

LCW 50/200

BAND WRAPPING LABELING SYSTEM

Product diameter from 15mm to 150mm¹
Up to 120 products per minute²
Built in stainless steel



32 product memories
Numeric keypad with LCD display

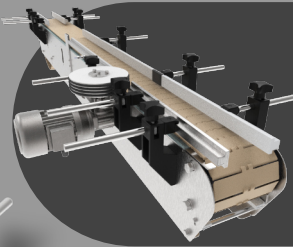

Variable speed with automatic synchronization
Adjustable side guides



KETAN ARGENTINA S.A.
Av. Eva Perón 3491, San Martín (1650)
Buenos Aires - Argentina
Tel/Fax: (54 11) 5197-8587
E-mail: info@ketan.com.ar



¹ The product to label must be able to keep itself stable. For unstable products contact us.
² It depends on the length of label and diameter of bottle.

LCW 50/200

BAND WRAPPING
LABELING SYSTEM

DIMENSIONS

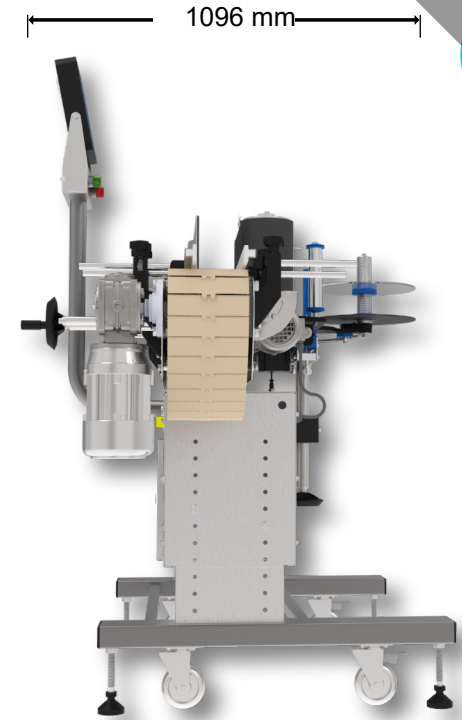
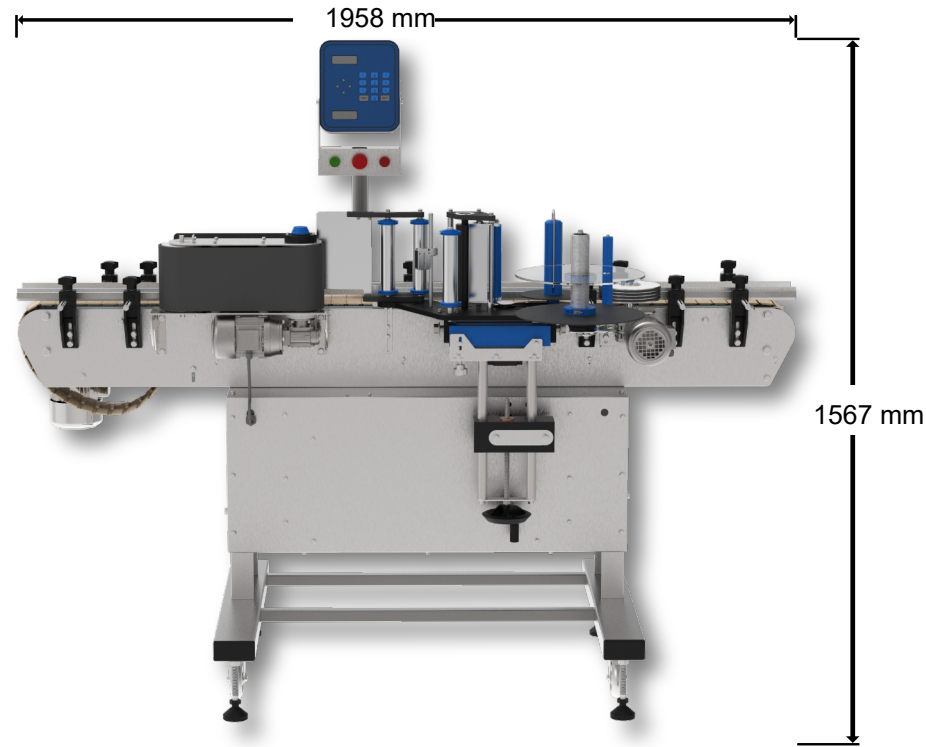

Left Version

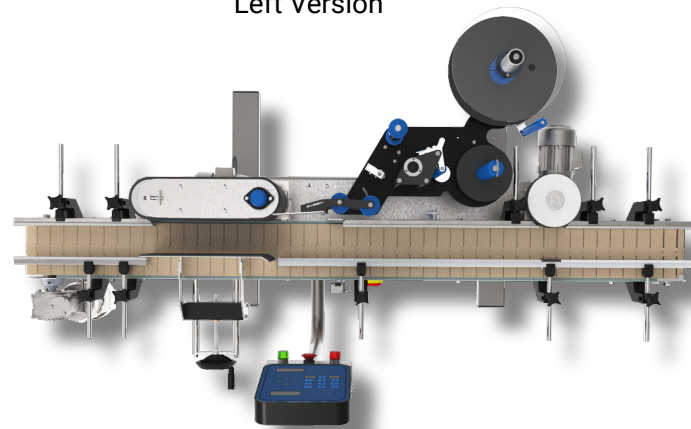

Right Version

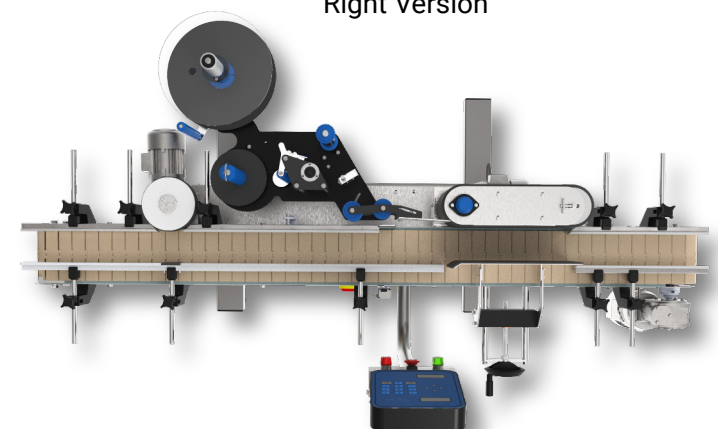

LCW 50/200

BAND WRAPPING
LABELING SYSTEM

SPECS

Compatible heads	K50, K200, KFLEX
Labeling capacity	Up to 120 labels/min depending on label length
Labeling speed	1-30 m/min
Label width	Up to 115 or 170 mm depending on the labeling head
Label length	Up to 280 mm
Paper roll inner diameter	76 mm
Paper roll outer diameter	Up to 300 mm
Transport width	152.4 mm (6 in) standard. Possibility of customized transport widths on request
Product Diameter	15-150 mm standard. Possibility of larger diameters on request
Power supply	1.5 kVA 220V-240V, 50Hz* 110V-120V, 60Hz*
Weight (kg)	200
Dimensions (mm)	1958 x 1096 x 1567

* The equipment is only compatible with one type of electrical supply. You must select the appropriate power supply when placing your order.



KETAN ARGENTINA S.A.

Av. Eva Perón 3491, San Martín (1650)

Buenos Aires - Argentina

Tel/Fax: (54 11) 5197-8587

E-mail: info@ketan.com.ar